



회사개요 (会社概要)

회사명 社名 Company Name	주식회사 다이약 株式会社ダイヤック Daiyac Corporation
소재지 所在地 Location	〒394-0084 長野県岡谷市長地片間町1-4-20 1-4-20 OSACHI-KATAMA-CHO OKAYASHI NAGANO TEL 0266-28-8868 FAX 0266-26-1186
회사설립 会社設立 Established	平成元年 1989년 4월 1 일 April 1, 1989
자본금 資本金 Capital	2,000万円 ¥ 20 million
대표자 代表者 President	대표이사 오구찌유우지 小口裕司 Yuji Oguchi
업종 業種 Sector	콜렛척, 가이드부쉬등 관련제품판매 Manufacture and Sales of Collet Chucks, Guide Bushes and Related Products
ISO	ISO9001 · ISO14001인증취득
제조회사 製造 Manufacturer	주식회사 다이야정기제작소 株式会社ダイヤ精機製作所 Daiya Seiki Co., Ltd.



일본본사 전경 (日本本社全景)

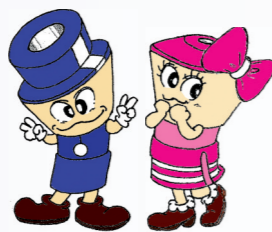

<http://www.daiyac.com/>

중국공장

中国工場 DAIYA SEIKI (CHANGSHU) CO.,LTD.
大雅精密机械(常熟) 有限公司
〒215500
江蘇省常熟東南經濟開發區富春江東路六十九号
常熟佳源置工業坊内
TEL 0512-5235-8781 FAX 0512-5235-8785
URL:<http://www.daiyac.com.cn/>

Add:NO.1 Lushan Road,East-South
Development, District, Changshu City
Jiangsu, 215500, CHINA



COLLET CHUCK & GUIDE BUSH



한국부산사무소 주식회사 다이약

(우 49219) 부산광역시 서구 보수대로145 (동대신동1가 320-3)
미소지음 오피스텔 201호
Mobile. 010-6449-1186 Fax. 051-797-8622
E-mail. vogue222@hanmail.net

Korea Office DAIYAC CORPORATION

MISOJIEUM Officetel 201, (320-3 Dongdaesin-dong 1-ga),
Bosu-daro 145, Seo-gu, Busan 49219, Korea
Mobile. +82-10-6449-1186 Fax. +82-51-797-8622
E-mail. vogue222@hanmail.net



주식회사 다이약



회사안내

당사는 콜렛 · 가이드부쉬의 판매를 전문으로 하고 있습니다. 표준콜렛은 물론이고, 초경콜렛을 비롯해 스틸콜렛, 극소경척, 전용기콜렛, 드릴용콜렛 등, 고객님의 원하는 사양에 맞추어 설계 및 제작이 가능합니다. 또한 척유닛, 미세가공용 스펀들과 내면 연삭용 휠, 척슬리브 등도 여러분의 요구에 부응하여 제공하고 있습니다.

다이약의 모회사인 다이아정밀제작소는 창업 이래 60년이상, 정밀 절삭 가공 기술을 기축으로 한 회사로서, 특히 연구개발 및 선진적인 생산설비등, 높은 신뢰성이 요구되는 제품을 전문으로 하고 있습니다. 오랜 경험과 노하우의 축적에 의한 당사의 기술은 많은 고객으로부터 높은 평가와 지지를 받고 있습니다. 앞으로도 당사의 뛰어난 기초기술력에 더욱 완성도 높은 새로운 기술개발을 목표로 도전할 계획입니다.

당사는 일찍부터 국제 규격 ISO9001을 인증하고, 고객에게 안심하고 사용 할 수 있는 제품을 제공 할 수 있도록 고품질 보증체제를 구축하고 있습니다. 또한 2002년에는 ISO14001을 인증하고 한정된 자원을 효율적으로 사용하고 유해한 물질을 제거하는 친환경 활동에도 최선을 다하고 있습니다.

전 직원이 하나되어 고객님의 요구에 부응 할 수 있도록 노력하겠습니다.

会社案内

弊社はコレットチャック・ガイドブッシュの販売を主に手がけ、お客様にご満足頂けるようお応えしております。超硬コレットチャックをはじめ、スチール製コレットチャック、極小径チャック、専用機のコレット、ドリル用コレット等、標準品はもとより、ご希望の仕様に合わせた、1個からの設計、製作もお受けしております。また、チャックユニット、微細加工用スピンドルや内面研削砥石用クイル、チャックスリーブ等も皆様のご要望にお応えし、ご提供しております。

生産親会社である、株式会社ダイヤ精機製作所は創業以来60年以上、精密切削加工技術を基軸としたものづくりの会社で、特に研究開発や試作、高度な生産設備等における高い信頼性が要求される製品を得意としております。長い経験とノウハウの積み重ねによる弊社の技術は多くのお客様からご支持をいただいております。これからもこの強い基盤技術の上にさらに磨きをかけるべく、新たな技術の開拓と挑戦を続けていきたいと思っております。

弊社は早くから国際規格ISO9001を認証取得し、お客様に安心して頂ける高品質をご提供できますように高水準の品質保証体制を構築しています。また、2002年にはISO14001も認証取得し、限りある資源を有効に利用し、有害な物質を排除し、地球に優しいものづくりに取り組んでいます。

全社員が、お客様のご要望にお応えできるよう努力してまいります。

Daiyac Corporation in a Nutshell

Daiyac's main operation is the sales of collet chucks and guide bushes most satisfying to its clientele. While its principal thrust is carbide collet chucks, its offerings cover steel collet chucks, ultra-small-diameter chucks, collets for dedicated machinery, and collets for drills. Standard models are available, of course, but we can also respond with the design and manufacture of even a single piece of product if it should help out our customer in need. Our product lines also range over chuck units, microfabrication spindles, quills for internal grinding wheels, chuck sleeves, etc., to cover various customer requirements.

Daiyac is operating in close cooperation with Daiya Seiki Co., Ltd., its parent company. Having a corporate history of over 60 years, Daiya Seiki is a manufacturer well-reputed for its precision machining technologies. Its area of specialty is R&D and test production as well as production of advanced production machinery featuring high reliability. Thus we enjoy unwavering support of a large clientele for our products built upon our abundant experience and know-how. We will keep tackling the challenge of not only refining our own technologies but also opening up new realms of technologies.

From early on, we made sure to obtain ISO9001 certification. We endeavored to structure a most reliable quality assurance system in order to win customer confidence by offering high-quality products only. In 2002 we acquired the ISO14001 certification, and 'The Earth-friendly manufacturing' has always been our motto in making effective use of limited natural resources and eliminating the use of harmful materials.

So please be assured that all the Daiyac employees are united in their efforts to present you with products most satisfactory in your eyes.

COLLET CHUCK

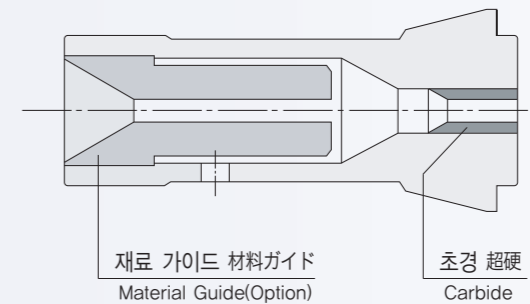

GUIDE BUSH

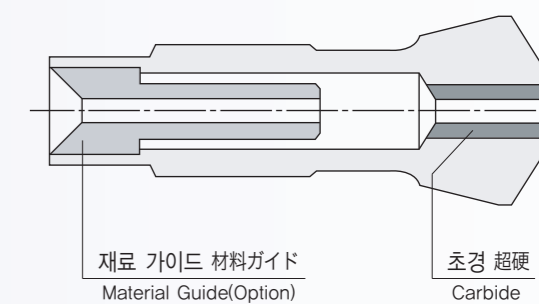

● 고정도 · 고품질

高精度 · 고품질 High Accuracy and High Quality

당사 공장에 의한 순 일본제로서, 높은 정밀도와 안정된 품질을 제공하고 있습니다.

当社工場による純日本製のため、高い精度と品質を安定して提供します。
High accuracy and quality are offered due to the use of all Japanese made parts in our factory.

● 신뢰의 근거 검사표

信頼の裏付け、精度検査表 Accuracy Inspection Sheet, a Proof of Reliability

모든 제품에 검사표를 첨부하여, 정도(精度)를 확인할 수 있습니다.

すべての製品に精度検査表がついていますので、精度をご確認いただくことができます。
Every product of ours comes with an accuracy inspection sheet, which assures you of its accuracy

チャック検査表	
月 日	
品 名	
サイズ	
口元	先端
x̄	

품질보증(ISO9001)에 근거한 생산
〈 검사표 〉
Inspection Table Sheet

사이즈 구분 사이즈区分 Bore Size	측정위치 測定位置 Measuring Position	표준 標準(mm) Standard	고정밀도 高精度(mm) High precision
2.99mm이하 2.99mm 以下 2.99mm or Below	선단끝위치 口元 / End Position	0.005	0.003
	10mm앞 10mm先 / 10mm Away	0.006	0.005
3.00mm이상 3.00mm 以上 3.00mm or Above	선단끝위치 口元 / End Position	0.005	0.003
	20mm앞 20mm先 / 10mm Away	0.008	0.005

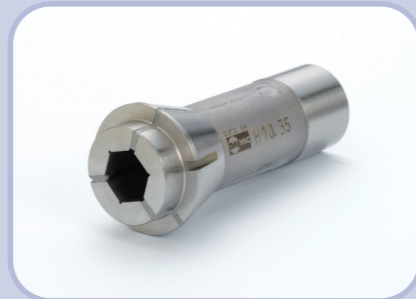
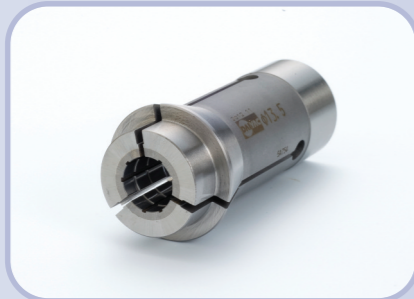
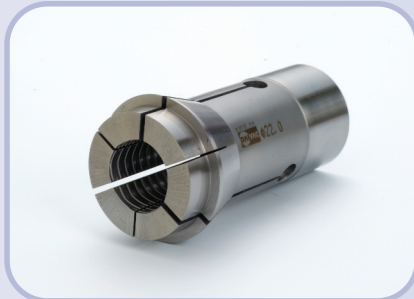
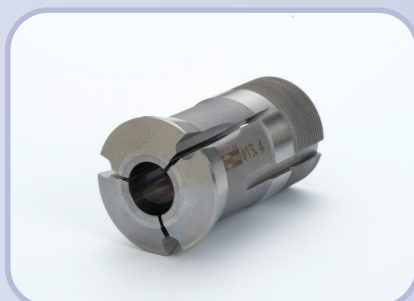

자동선반 대응가능 기종 自動盤コレットチャック対応メーカー
CITIZEN, MIYANO, STAR, TSUGAMI, NOMURA, HANWhA