

Centering drill with insert

- A single tool-holder and insert for all types of centering from \varnothing 1 to 5 mm
- 2 centering tips available
- 60° / 90° / 120° tips
- Very profitable price

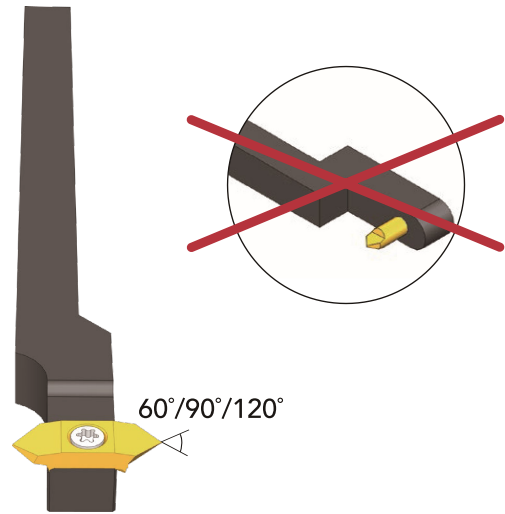

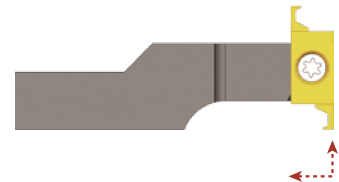

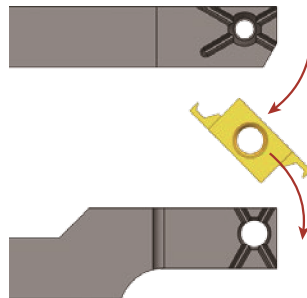
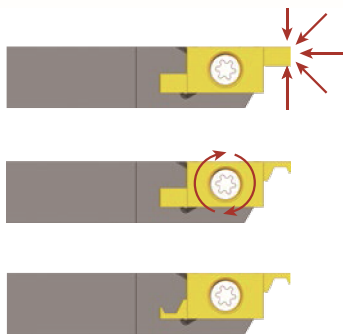
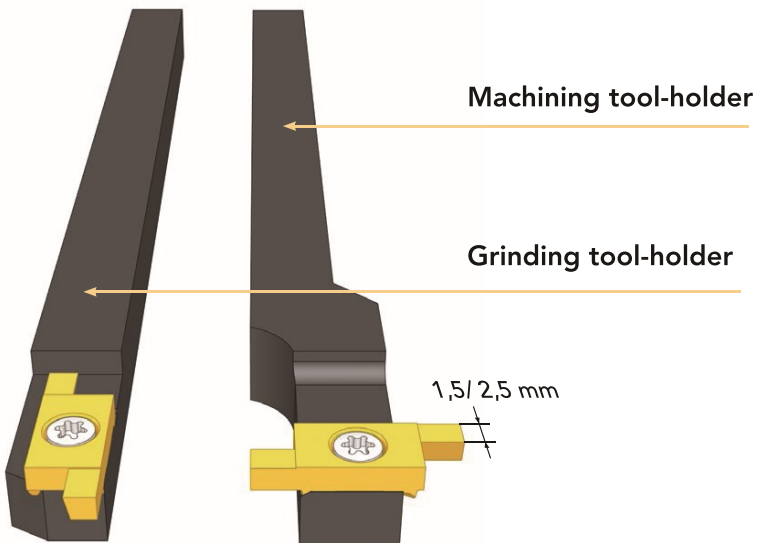







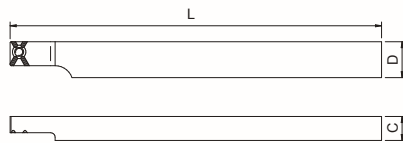

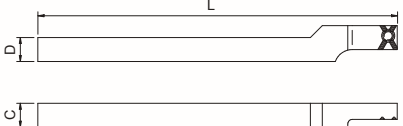

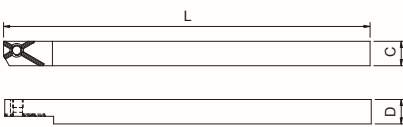
Hook tool-holder with insert

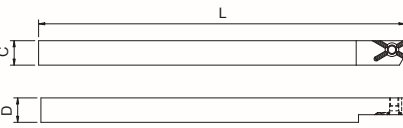

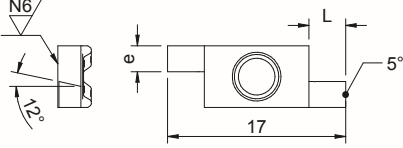
1. Sharpening of the 2 cutting edges of the pre-rectified blank on the grinding tool-holder.

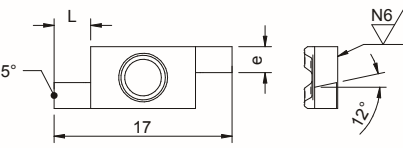
2. Transfer of the grinded blank on the machining tool-holder.

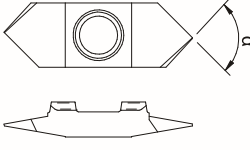
3. Use of the insert set up on the machining tool-holder same as a standard hook tool-holder.

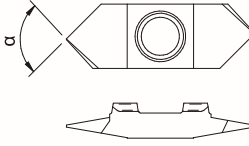
4xxxxR	Right machining tool-holder	Section CxD	Length L	Article nr.		
		8 x 12	120	40812R		
		10 x 12	120	41012R		
		12 x 15	120	41215R		
		16 x 16	120	41616R		
4xxxxL	Left machining tool-holder	Section CxD	Length L	Article nr.		
		7 x 7	120	40707L		
		8 x 8	120	40808L		
		12 x 12	120	41212L		
4xxR	Right grinding tool-holder	Section CxD	Length L	Article nr.		
		8 x 8	120	408R		
		10 x 10	120	410R		
		12 x 12	120	412R		
4xxL	Left grinding tool-holder	Section CxD	Length L	Article nr.		
		8 x 8	120	408L		
		10 x 10	120	410L		
		12 x 12	120	412L		
421R	Right blank insert	e	L	Article nr.	K10	BI40
		1,5	3,5	421R1,5	✓	✓
		2,5	3,5	421R1,2	✓	✓
421L	Left blank insert	e	L	Article nr.	K10	BI40
		1,5	3,5	421L1,5	✓	✓
		2,5	3,5	421L2,5	✓	✓
422R	Right insert	α	Article nr.	K10	BI40	
		60°	422R - 60° -	✓	✓	
		90°	422R - 90° -	✓	✓	
		120°	422R - 120° -	✓	✓	
422L	Left insert	α	Article nr.	K10	BI40	
		90°	422L - 90° -	✓	✓	